



SCHIER

**LIFETIME GUARANTEED
GREASE INTERCEPTORS**

INSTALLATION GUIDE

Model FCR1 Field Cut Riser

For Use with Grease Interceptors Models GB1, GB2 and GB3

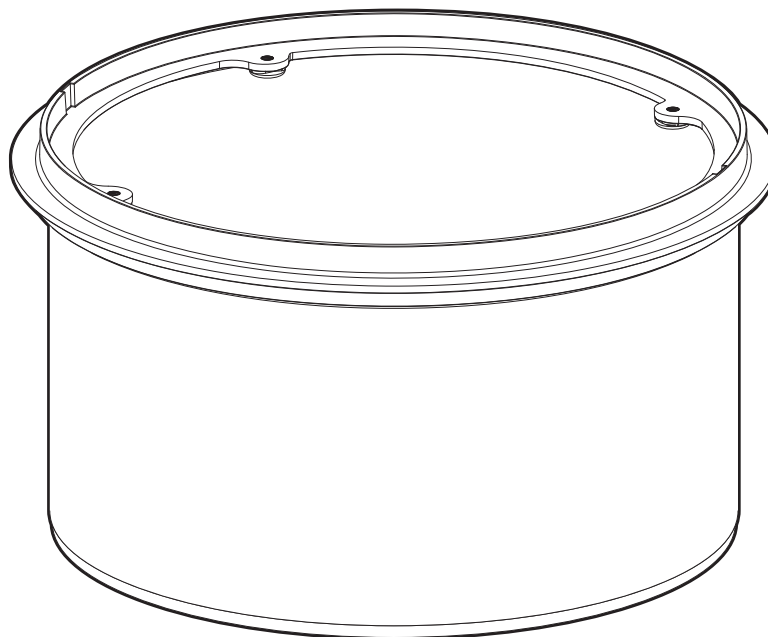

Contents

Special Precautions	2
Getting to Know the FCR1	3
Installation	4-5



SPECIAL PRECAUTIONS

For All Schier Grease Interceptor Installations - Failure to follow this guidance voids your warranty

Installation Instructions

Installation instructions and additional components are included with the interceptor. Read all instructions prior to installation. This interceptor is intended to be installed by a licensed plumber in conformance with all local codes.

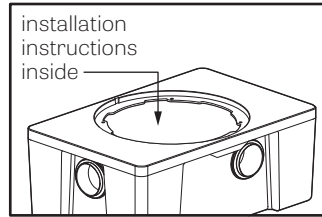

When Installing Interceptor Inside

If your dishwashing sink(s) discharges into a floor drain/sink (drain), you must regulate the flow into the drain to avoid an overflow of water onto the kitchen floor. This can be done by installing a valve or flow restriction cap on the sink piping that discharges into the drain. See drawing above for guidance. For detailed guidance on indirect connections, go to:

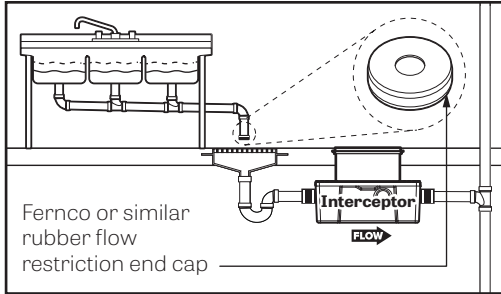

http://webtools.schierproducts.com/Technical_Data/Indirect_Connections.pdf

Flush-to-Grade Burials

Flush-to-Grade buried installations (without a riser) are not recommended for heavy foot traffic areas without the use of an internal support system (sold additionally).

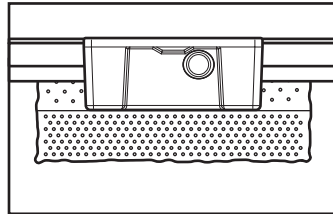

High Temperature Kitchen Water

If water is entering the interceptor at excessive temperature (over 140° F), a drain water tempering valve (DTV) and approved backflow prevention assembly must be installed. Most state and local plumbing codes prohibit water above 140° F being discharged into the sanitary sewer. Water above 140° F will weaken or deform PVC Schedule 40 pipe, poly drainage fixtures like interceptors and erode the coating of cast iron (leading to eventual failure).

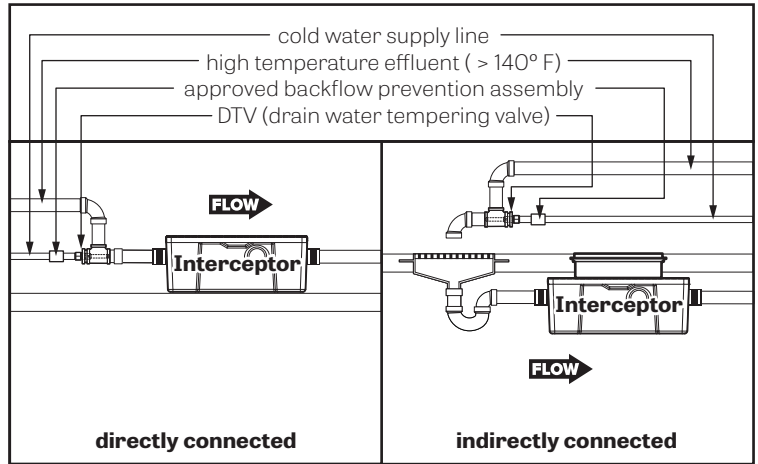

Fully Support Base of Unit

Install unit on solid, level surface in contact with the entire footprint of unit base; for suspended installations design trapeze to support the wet weight of the unit. Do not partially support unit or suspend unit using metal U-channel to create a trapeze

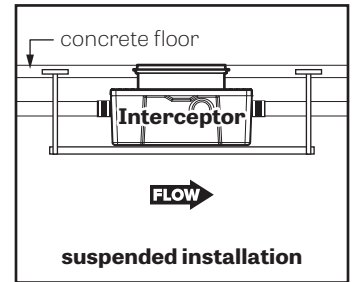

Support Inlet and Outlet Piping

For above grade installations ensure heavy inlet and outlet piping (such as cast iron or long runs) is properly supported or suspended during the entire installation process to prevent connection failure or damage to bulkhead fittings.

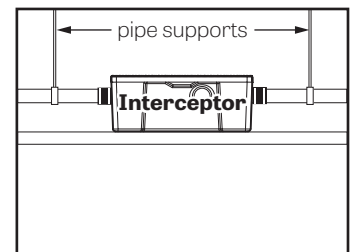

GETTING TO KNOW THE FCR1

Take a few moments to familiarize yourself with the FCR1.

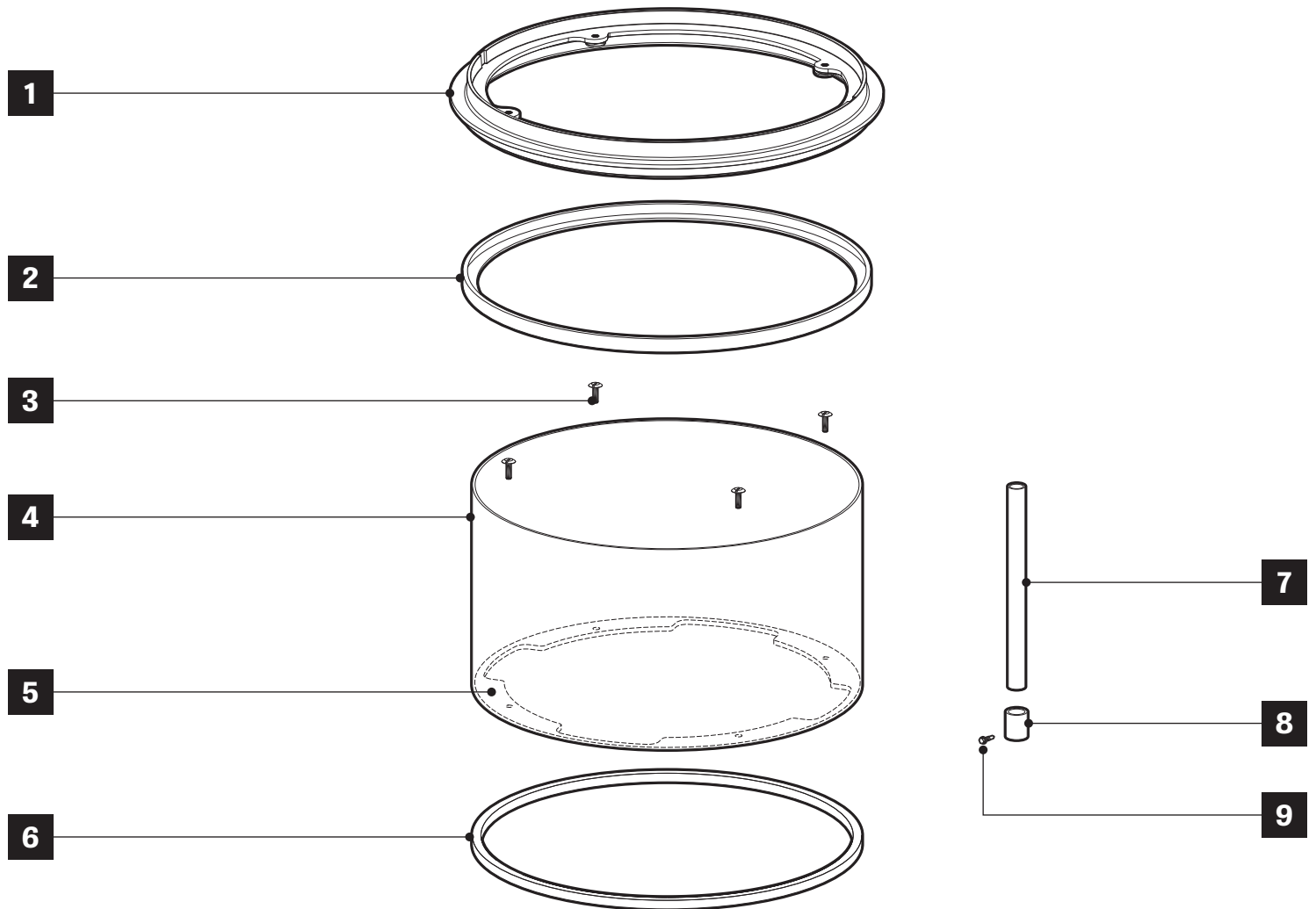

- | | |
|---------------------------------|--|
| 1. Cover Ring | 6. Riser Body Gasket |
| 2. Cover Ring Gasket | 7. Diffuser Access Riser (x2) |
| 3. Riser Mounting Bolts | 8. Diffuser Access Coupling (x2) |
| 4. Riser Body | 9. Diffuser Access Set Screw (x2) |
| 5. Riser Mounting Flange | |

INSTALLATION

Special Precautions

1

 **CAUTION**

Do not add any form of lubricant to riser tube during installation.

2

- Read all instructions before installation
- Install in conformance with all local codes

3

Max Water Level
Risers are not designed to retain water

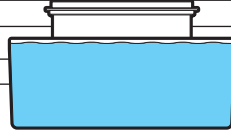

1 Determine number of risers needed

1a

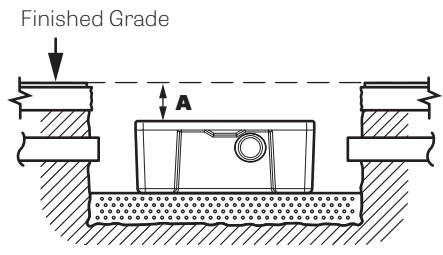

1b

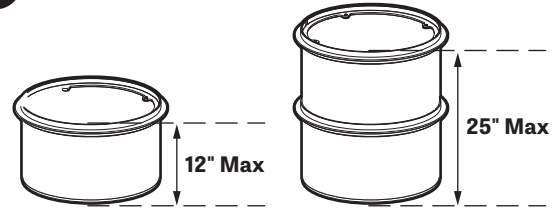

For the interceptor to be safely and properly maintained, dimension **A** cannot exceed 25" (or two FCRI risers stacked).

2 Mark and cut top-most riser

2a

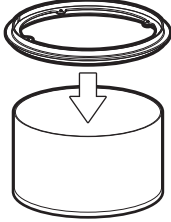

Push cover ring onto riser body until it stops (about 1").

2b

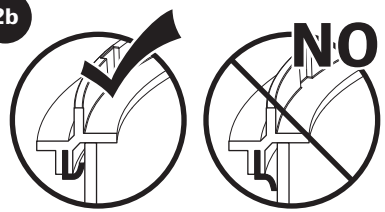

Ensure cover ring gasket is positioned as shown

2c

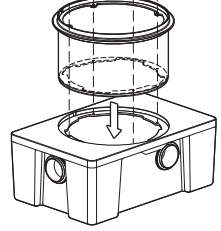

Place riser on interceptor, aligning bolt holes

2d

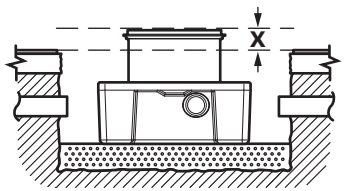

Measure "X" with tape measure.

2e

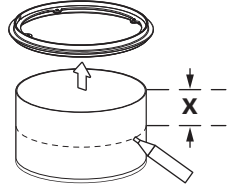

Remove cover ring from riser assembly and mark "X" with supplied grease pencil.

2f

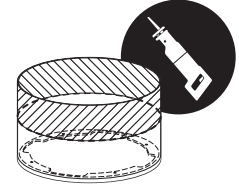

Cut "X" from top of riser and discard.

3 Fasten diffuser access risers

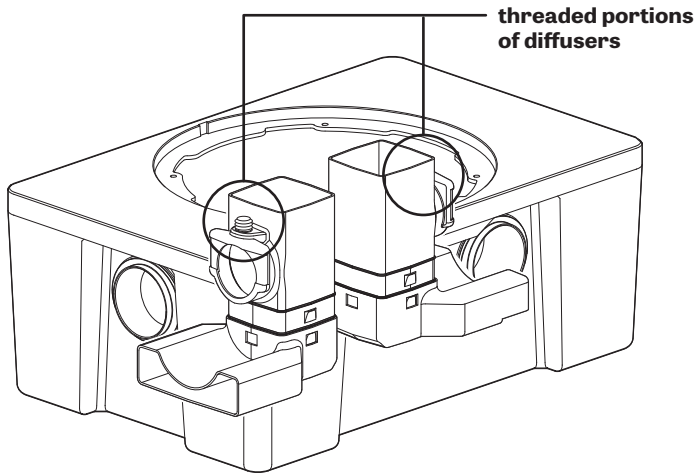

Push the diffuser access coupling onto the threaded portion of each diffuser and set using supplied set screw. Glue the diffuser access riser to each coupling.

NOTE: If stacking two FCR1 risers, you may also stack two diffuser access risers.

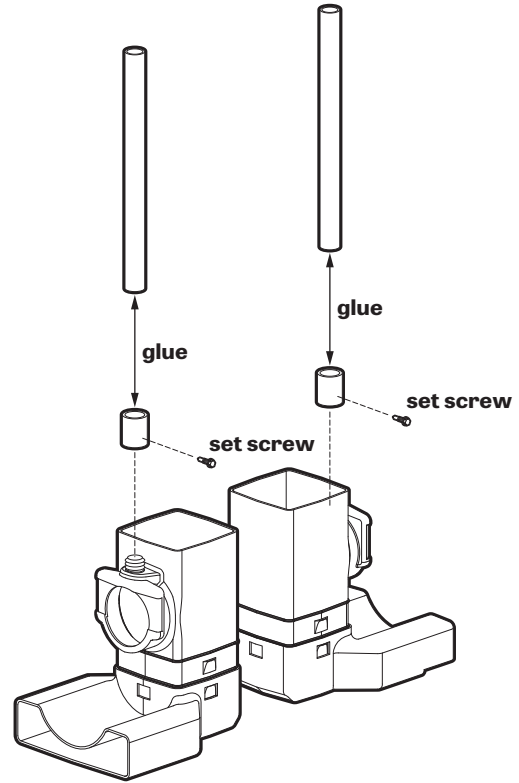

4 Fasten riser to interceptor

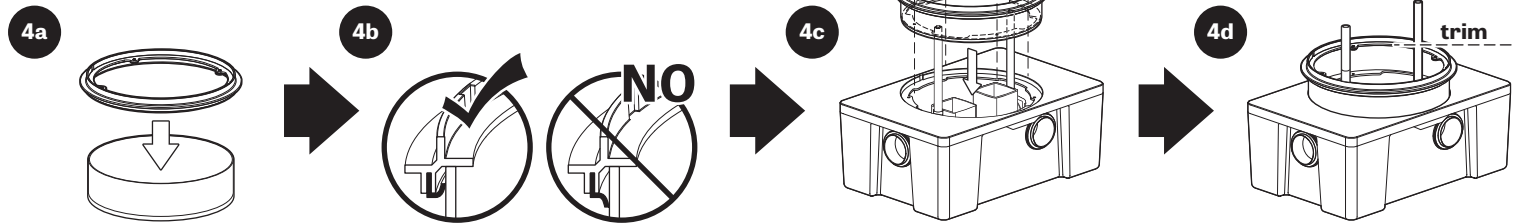

Remove any burrs or debris at the cut edge. Push cover ring onto riser body until it stops (about 1").

Ensure cover ring gasket is positioned as shown.

Place riser on interceptor, aligning bolt holes and fasten securely with mounting bolts.

Trim off excess from diffuser access risers.

5 Prepare for backfill

Resume "Buried Installation" instructions for applicable unit (GB1, GB2 or GB3)